

Logano G144 Eco

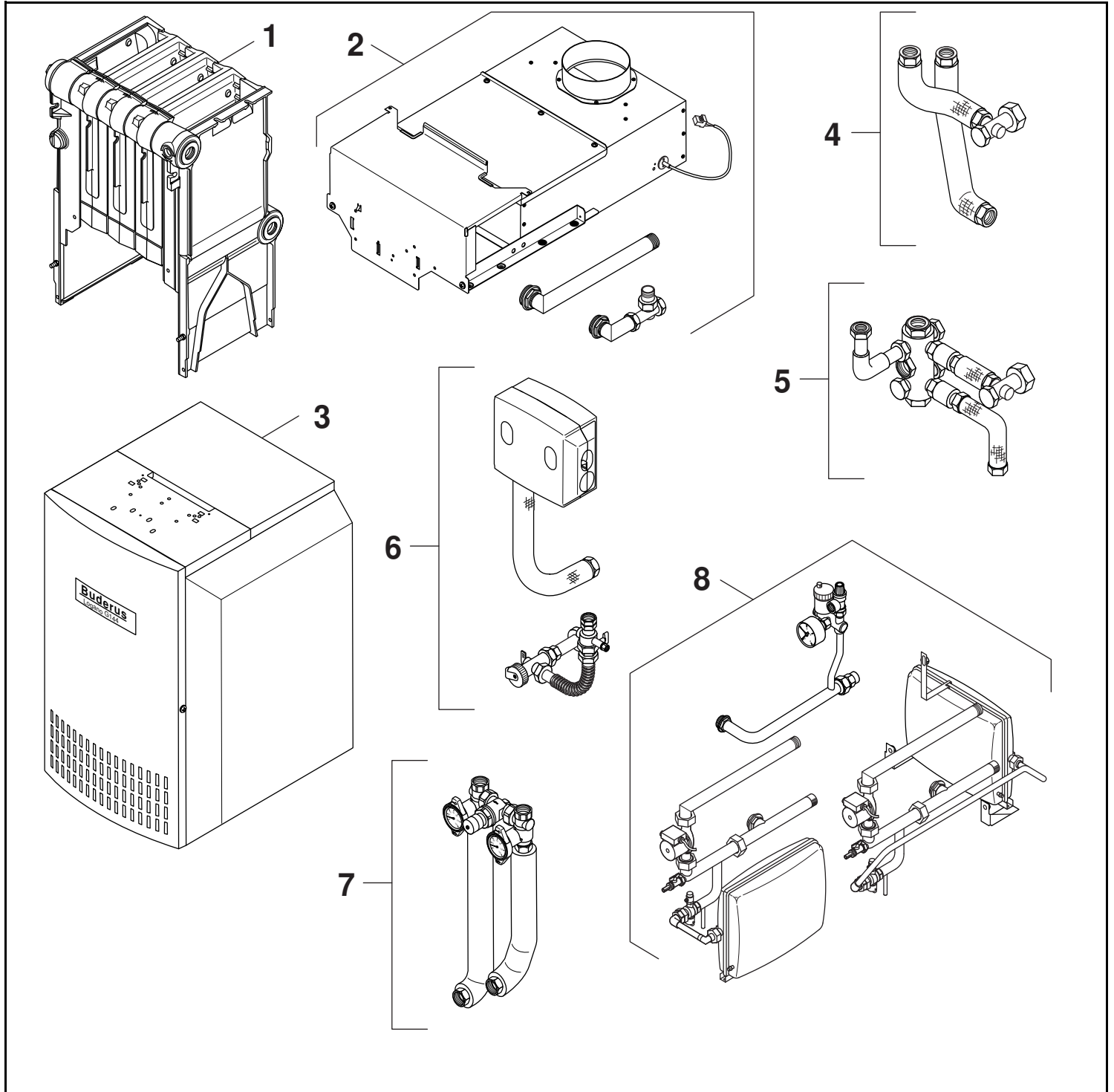

Buderus

Wichtige Hinweise

- Ersatzteile dürfen nur von einem zugelassenen Installateur eingebaut werden!
- Die genannten Preisgruppen können sich während der Gültigkeit dieser Ersatzteilliste ändern. Wir empfehlen Ihnen daher, die Preisgruppen anhand der jeweils gültigen Preisliste zu prüfen.
- Im Anhang finden Sie:
 - die Übersetzungen aller verwendeten Teilebezeichnungen
 - eine Übersicht der Gerätetypen und Länder, für die diese Ersatzteilliste gilt.

Important notes

- The spare parts may only be installed by an approved installer!
- The price groups quoted may change during the period of validity of this spare parts list. We therefore advise you to check the price groups against the current price list.
- In the appendix you will find:
 - a list of translations of the names of all parts used
 - a list of the models and countries to which this spare parts list applies.

Indications importantes

- L'installation des pièces de rechange doit être effectuée par un professionnel qualifié !
- Les groupes de prix indiqués peuvent changer durant la durée de validité de la présente liste des pièces de rechange. Nous vous recommandons donc de vérifier les groupes de prix au moyen de la liste de prix correspondante en vigueur.
- Veuillez trouver en annexe :
 - les traductions de toutes les désignations des pièces utilisées
 - une vue globale des types de chaudières et des pays pour lesquels la présente liste des pièces de rechange est valable.

Avvertenze importanti

- Le parti di ricambio possono essere montate esclusivamente da personale qualificato ed in possesso dei requisiti tecnico-professionali (L. 46/90).
- Durante il periodo di validità della presente lista ricambi, i gruppi inerenti i prezzi riportati, possono essere soggetti a cambiamenti. Pertanto, è sempre consigliata una verifica basata sul confronto tra i gruppi prezzi riportati ed il relativo listino prezzi in vigore.
- In appendice sono reperibili:
 - traduzione di ogni descrizione relativa alle varie parti di ricambio
 - elenco di sigle e codici, corrispondente ai vari paesi di destinazione.

Indicaciones importantes

- ¡Los repuestos solamente deben ser montados por los servicios técnicos oficiales de la marca!
- Los grupos de precios citados pueden sufrir alteraciones durante el período de vigencia de esta lista de repuestos. Recomendamos por ello contrastar los grupos de precios en base a las respectivas listas de precios vigentes.
- En el anexo podrá encontrar:
 - la traducción de todas las denominaciones de piezas empleadas
 - una relación de los tipos de aparato y países en los que se aplica esta lista de repuestos.

Belangrijke aanwijzing

- Onderdelen mogen alleen door een erkend installateur worden vervangen!
- De genoemde prijsgroepen uit de onderdelenlijsten kunnen worden vergeleken met de nu geldende prijsgroepenlijst. Aanbevolen wordt de prijslijst te controleren op de nu geldende data.
- In de bijlage vindt u:
 - de vertalingen van de gebruikte onderdelentekeningen
 - een overzicht van toesteltypen en de landen waarvoor deze onderdelenlijst bedoeld is.

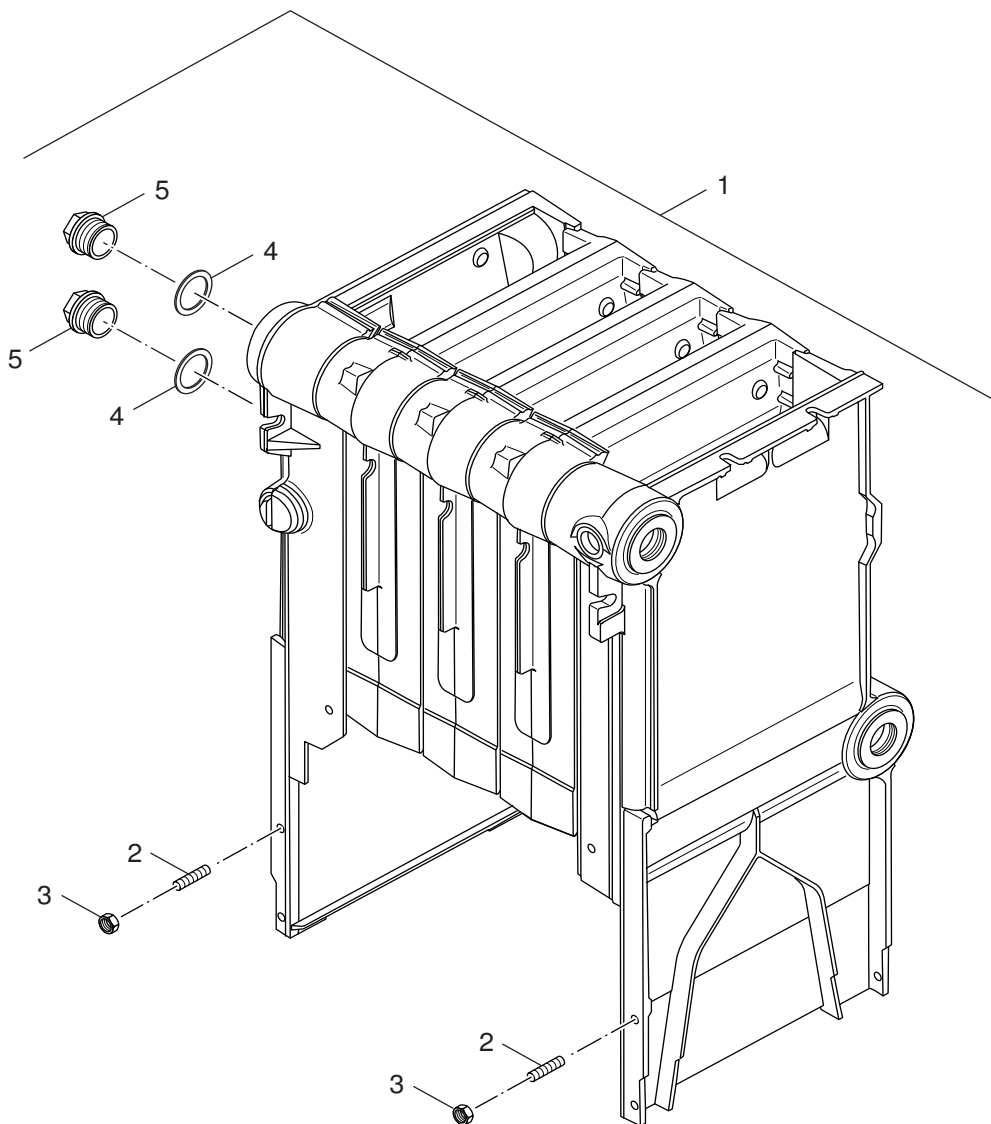

6720905005.aa.RS-Kesselblock G144 Eco

1

Kesselblock
Boiler block
Corps de chauffe
Corpo caldaia
Bloque de la caldera
Ketelblok

G144 13/3Eco- 32/5 Eco

Ersatzteilliste
Spare parts list

Liste des pièces de rechange
Lista parti di ricambio

Lista de repuestos
Onderdelenlijst

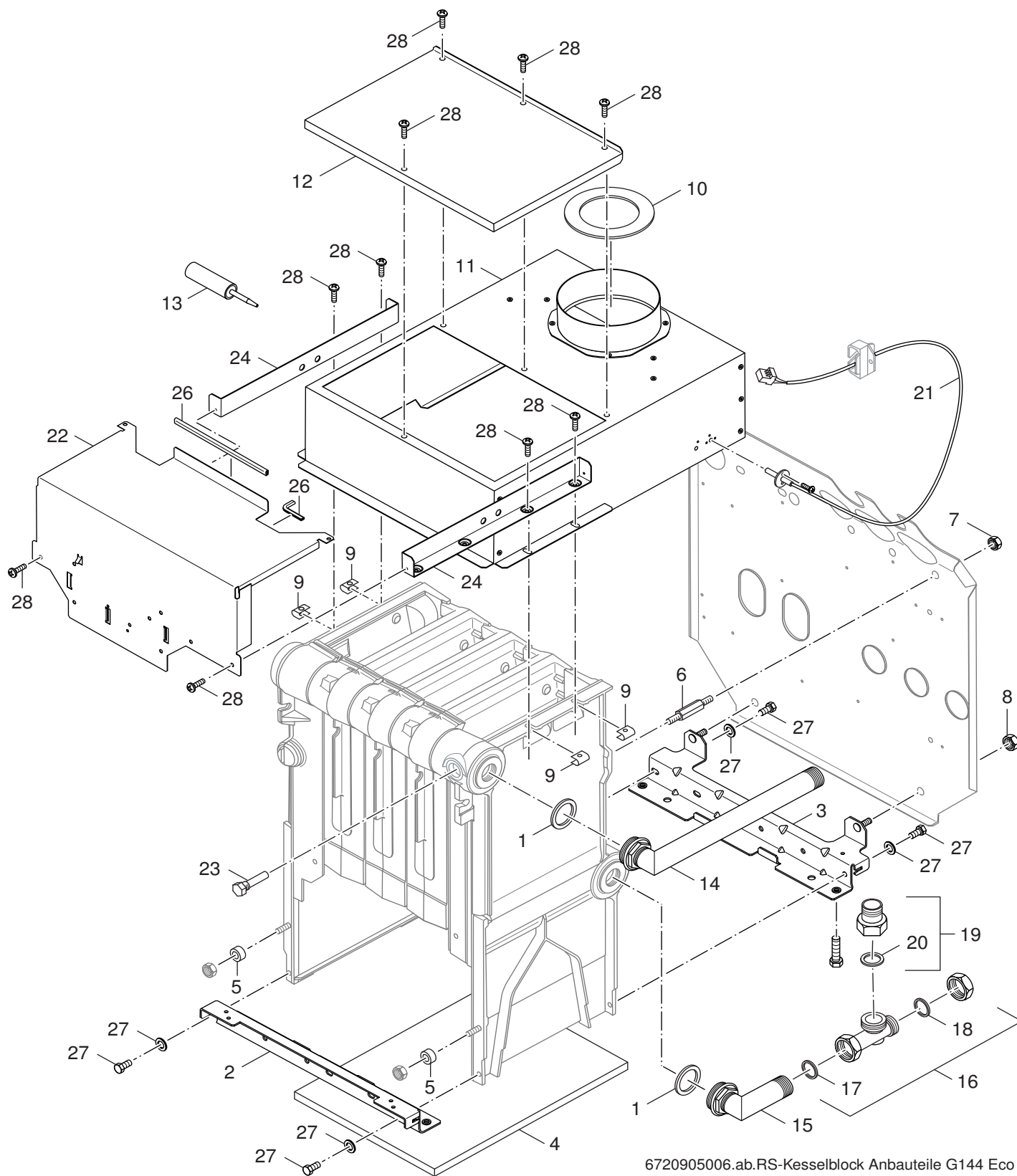

6720905006.ab.RS-Kesselblock Anbauteile G144 Eco

2

Kesselblock Anbauteile
Boiler block attachment
Corps de chauffe annexe
Corpo caldaia
Bloque de la caldera kit incluido
Ketelblok Anbouw

G144 13/3Eco- 32/5 Eco

Ersatzteilliste
Spare parts list

Liste des pièces de rechange
Lista parti di ricambio

Lista de repuestos
Onderdelenlijst

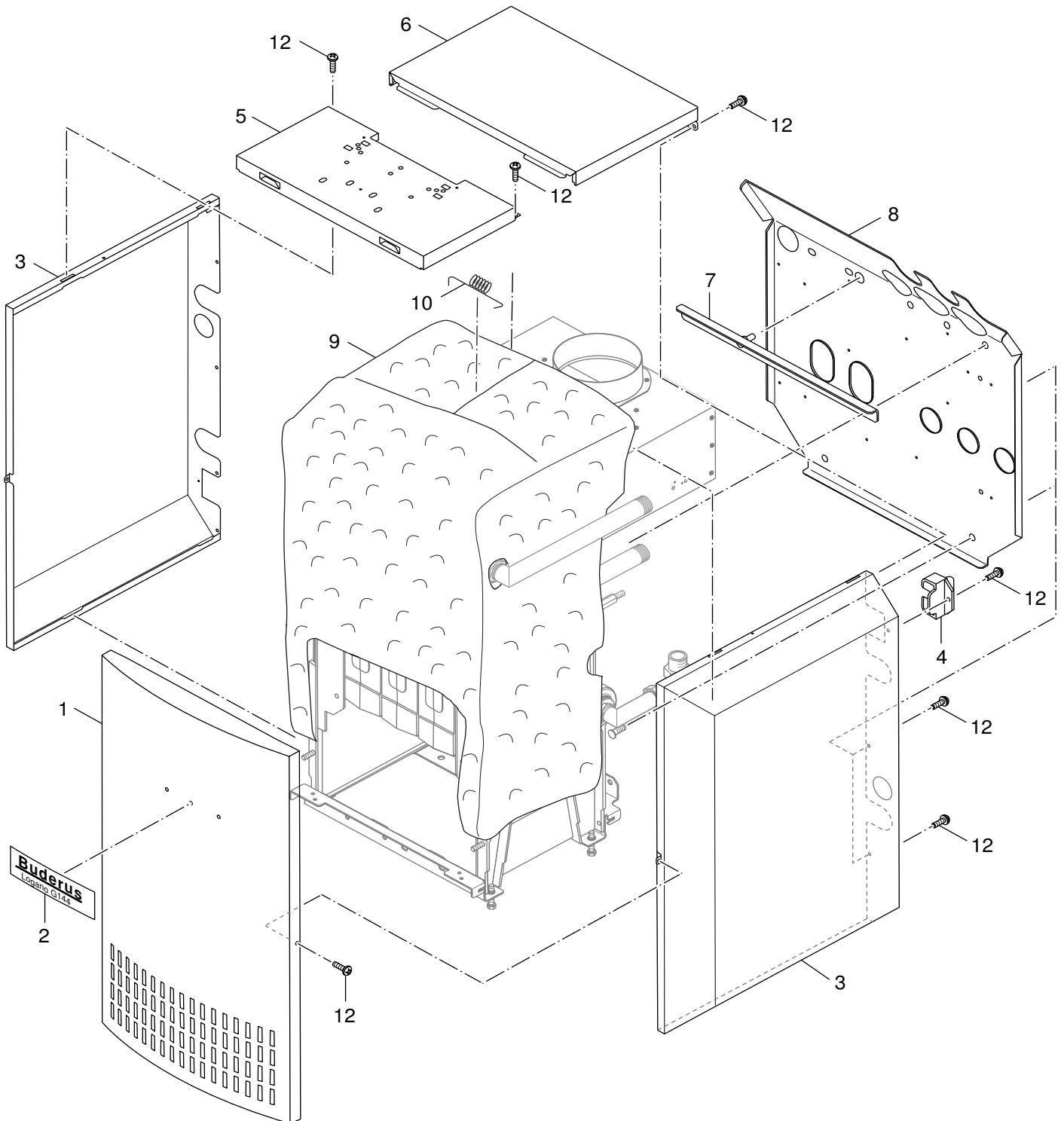

6720905007.aa.RS-Verkleidung G144 Eco

Verkleidung
Casing
Carénage

G144 13/3 Eco G144 13/3 V E 32/5 Eco

3

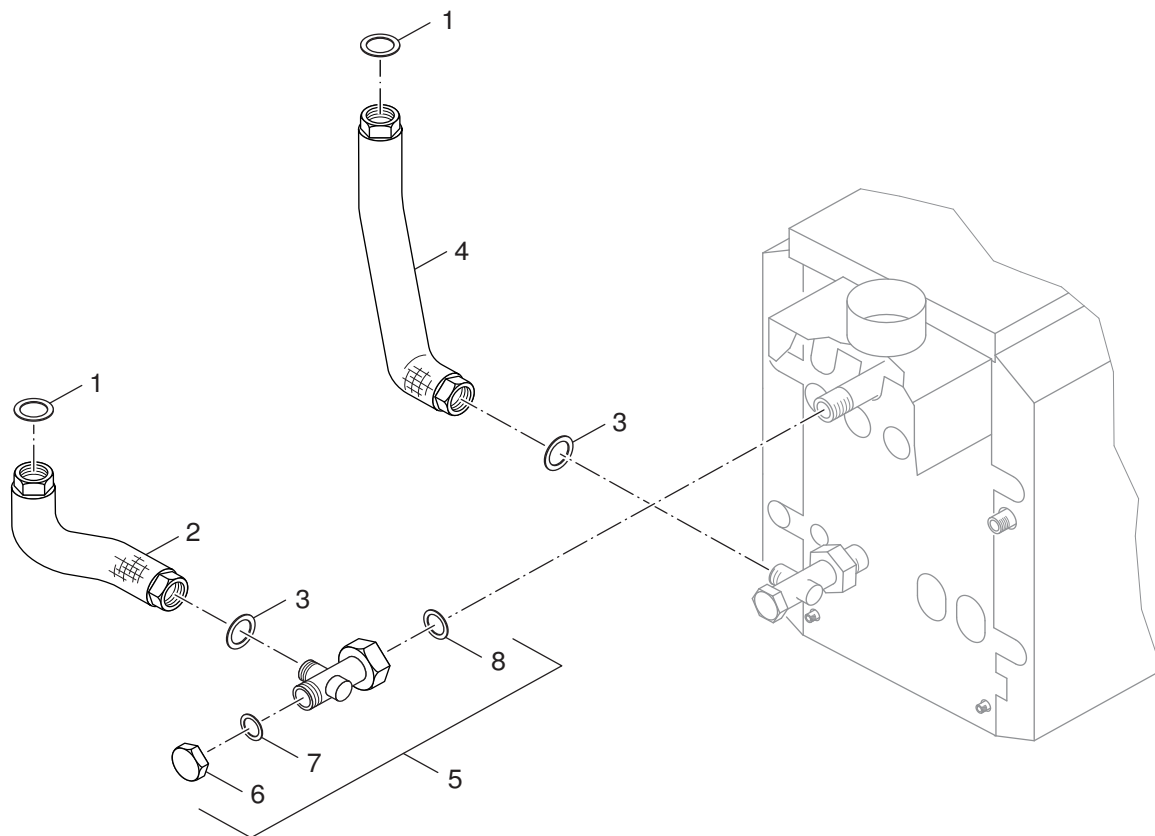

6720905008.aa.RS-Kesselanschluss-Set senkrecht KAS1 G144 Eco

4

Kesselanschl-Set senkr KAS1
Boiler connection KAS1
Raccordement chaudiere KAS1
Collegamento caldaia KAS1
Conexión de caldera KAS1
Ketelansluting KAS1

G144 13/3Eco- 32/5 Eco

Ersatzteilliste
Spare parts list

Liste des pièces de rechange
Lista parti di ricambio

Lista de repuestos
Onderdelenlijst

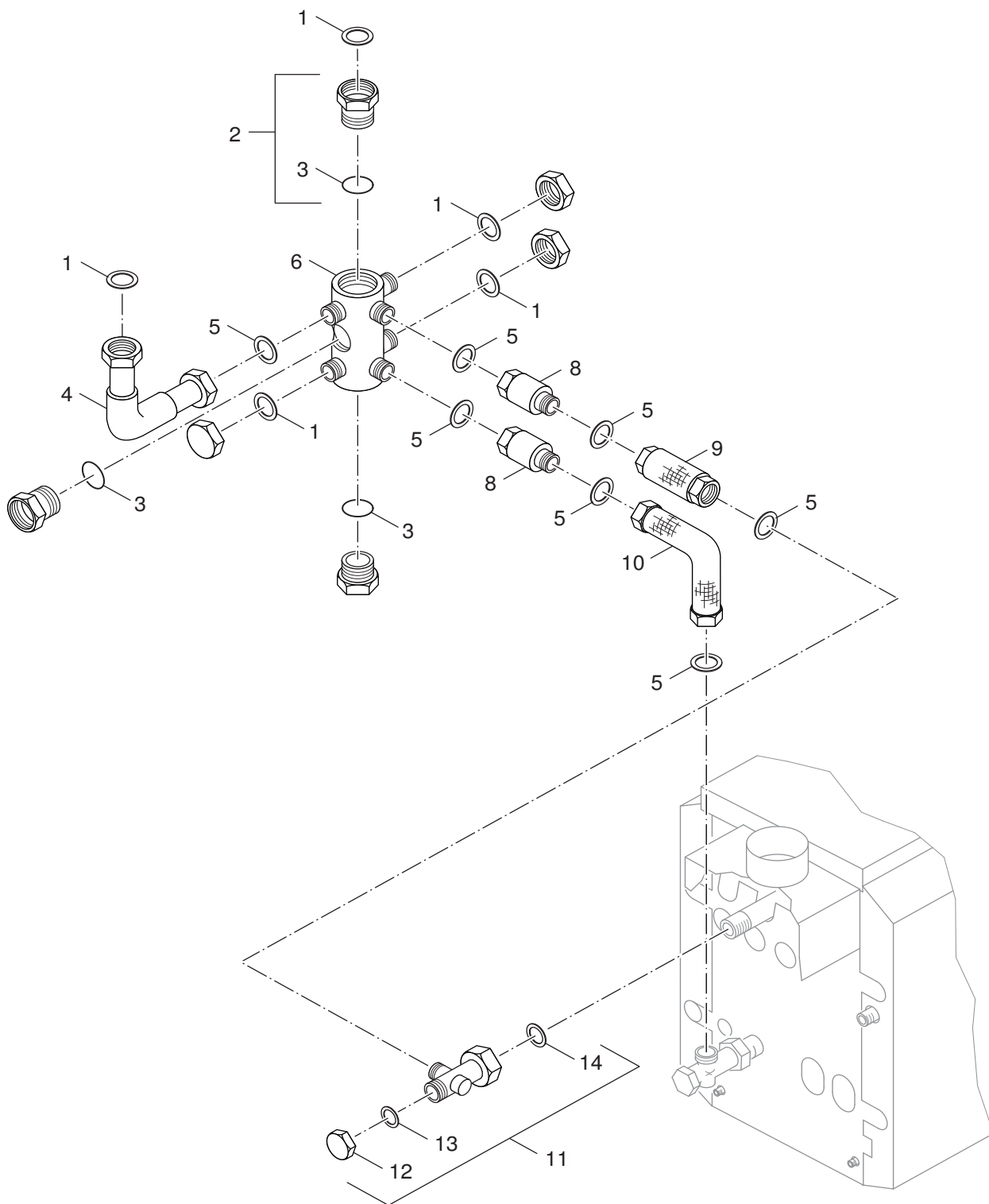

6720905009.aa.RS-Kesselanschluss-Set waagrecht KAS2 G144 Eco

5

Kesselanschl-Set waager KAS2
Boiler connection KAS2
Raccordement chaudiere KAS2
Collegamento caldaia KAS2
Conexión de caldera KAS2
Ketelansluting KAS2

G144 13/3 Eco- 32/5 Eco

Ersatzteilliste
Spare parts list

Liste des pièces de rechange
Lista parti di ricambio

Lista de repuestos
Onderdelenlijst

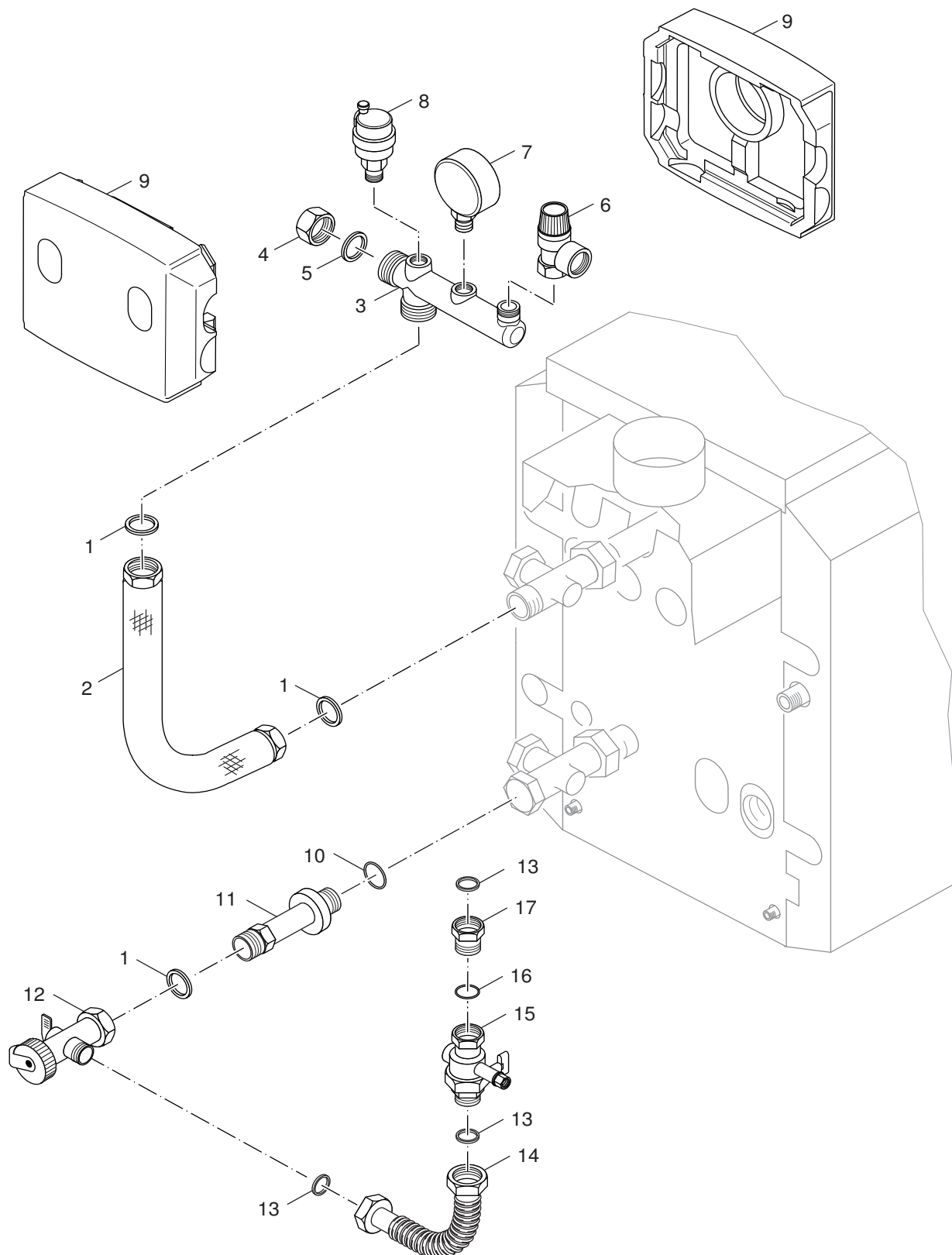

6720905010.aa.RS-Sicherheits-Set KSS, Ausdehnungs-Entleerungs-Set AAS G144 Eco

6

Sicherheitsset KSS Ausd/Entlset AAS
Safety group KSS
Groupe de securite KSS
Gruppo sicurezza KSS
Grupo de seguridad KSS
Zekerheidsgroep KSS

G144 13/3Eco- 32/5 Eco

Ersatzteilliste
Spare parts list

Liste des pièces de rechange
Lista parti di ricambio

Lista de repuestos
Onderdelenlijst

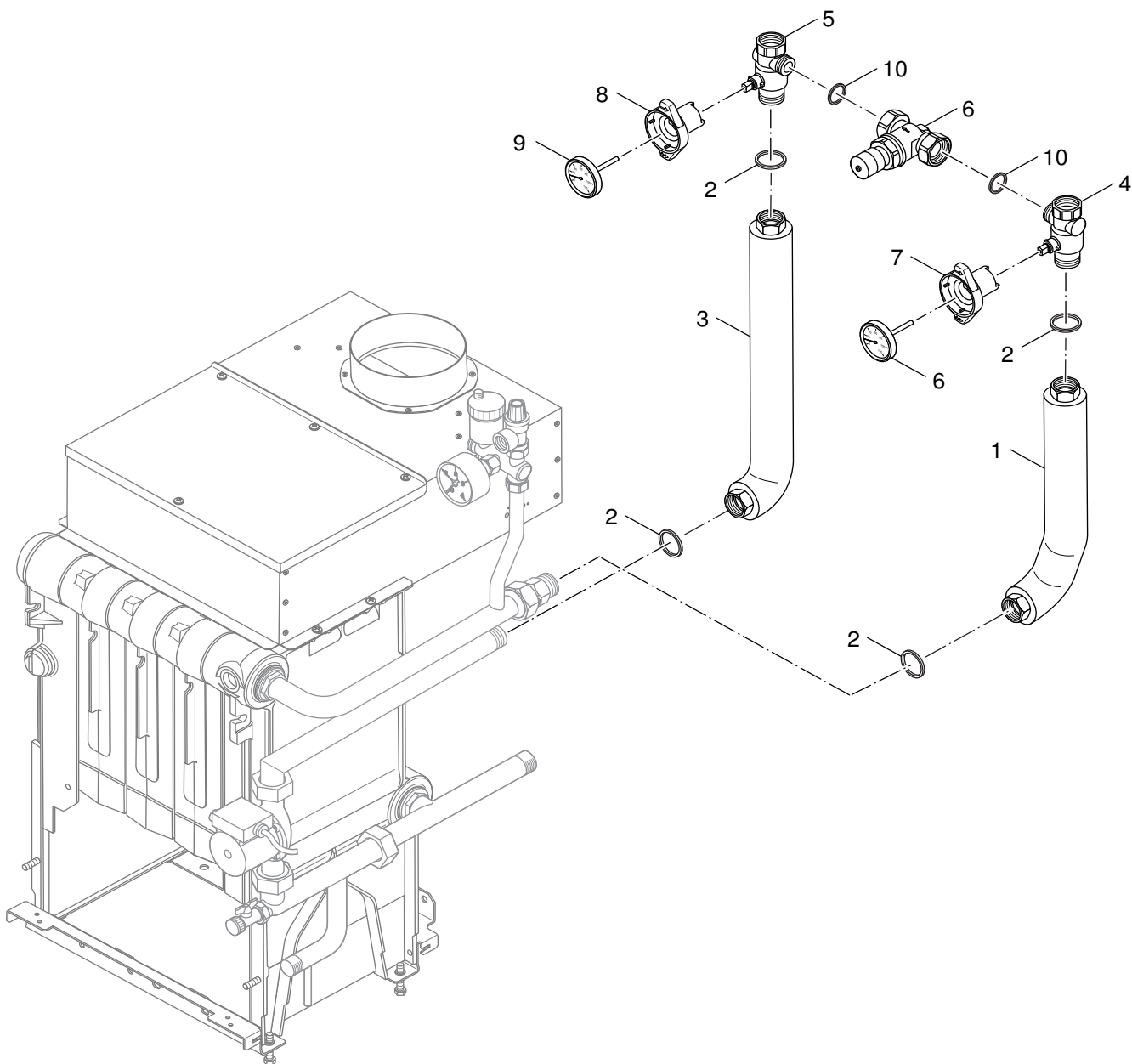

6720905011.aa.RS-Heizkreisanschluss-Set HS/V G144 Eco

7

Heizkreisanschlußset HS/V
Connection set HS/V
Kit de raccordement HS/V
Serie de collegamento HS/V
Juego piezas de conexión HS/V
Aansluitset HS/V

G144 13/3Eco- 32/5 Eco

Ersatzteilliste
Spare parts list

Liste des pièces de rechange
Lista parti di ricambio

Lista de repuestos
Onderdelenlijst

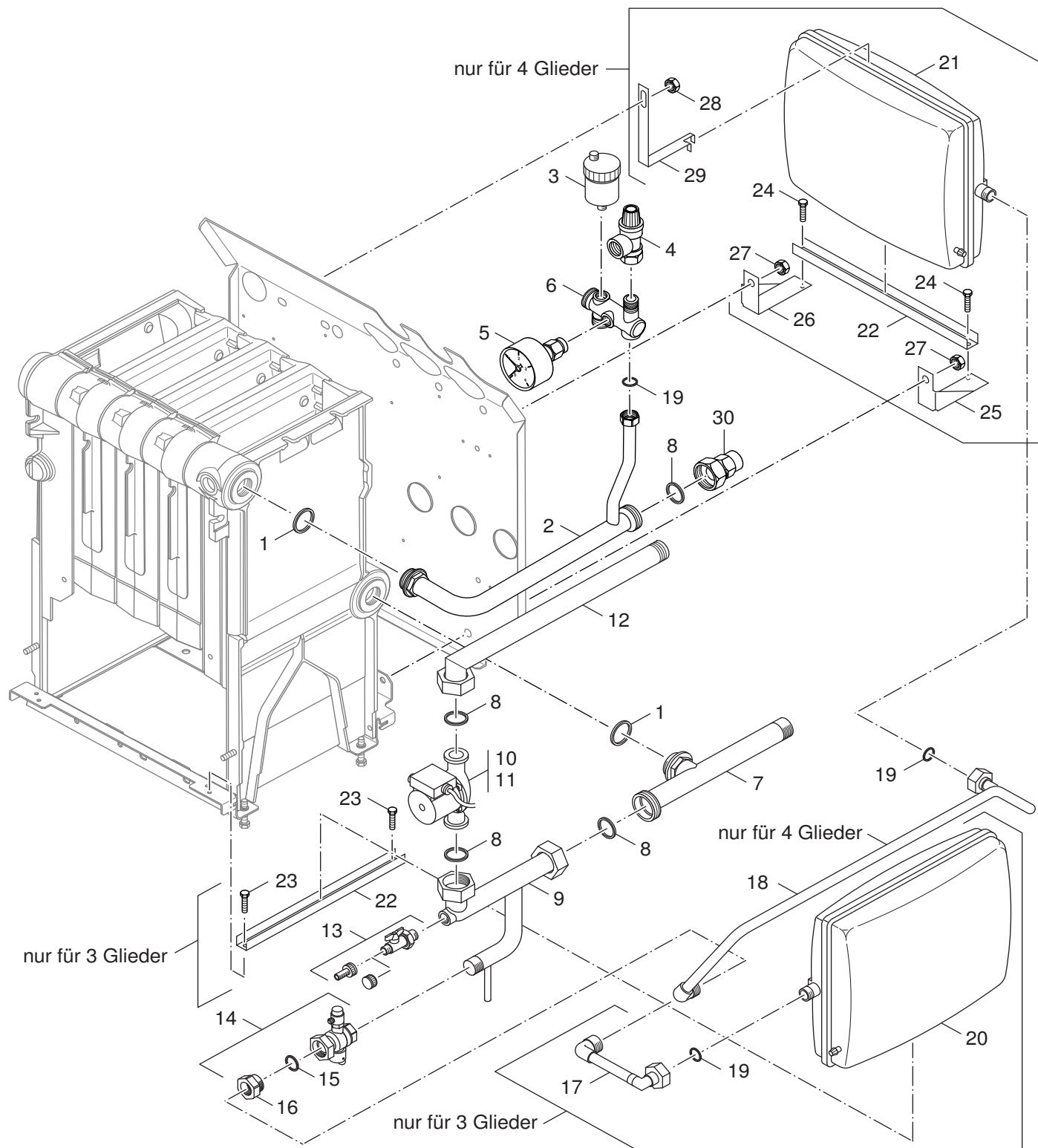

6720905012.aa.RS-Verrohrung mit Ausdehn-Gefäß und Pumpe G144 Eco

Verrohrung m Ausdehngefäß u Pumpe
pipework

G144 13/3Eco- 32/5 Eco

8

Übersetzungsliste
List of translations

Liste des traductions
Traduzione delle descrizioni

Lista de traducciones
Vertalinglijst

Pos	Description	Denomination	Descrizione	Descripción	Benaming
1	Element of construction	Groupe construction	Gruppo costruzione	Grupo construccion	Montagegroep
1	Boiler block G144 /V 3sect	Corps de chauffe	Corpo caldaia	Bloque de la caldera	Ketelblok
2	Stud DIN939 M8x30 5.6	GOUJON M8X30-5,6	Stud	Tornillo	Stud
3	Hex nut with locking gear	ECROU 6 PANS	Dado	Tuerca	Moer
4	Gasket AFM 34, white	JOINT TRAPPE DE NETT	Guarnizione	Junta	Afdichting
5	Blind plug forged version	Bouchon	Coperchietto	Tapon	Doorvoertule
2	Element of construction	Groupe construction	Gruppo costruzione	Grupo construccion	Montagegroep
1	Gasket AFM 34, white	JOINT TRAPPE DE NETT 04	Guarnizione	Junta	Afdichting
2	Bottom rail G124X	RAIL FIXATION G124X	Telaio	Respaldo	Strip
3	ground rail G124X rr/G144 rr	Barre	Telaio	Respaldo	Strip
4	Thermal insulation for head unit	ISOLATION		Aislamiento	
5	Spacer DN8x8	Entretoise DN8x8	Distanziale	Collar distanciador	Afstandshouder
6	Spacer bolts M8x63,5	VIS ENTRETOISE	Bullone	Perno	Bout
7	Hex nut with locking gear	ECROU 6 PANS	Dado	Tuerca	Moer
8	Hex nut	Ecrou	Dado	Tuerca	Moer
9	Snap nut 4,8-SNU2012	ECROU 4,8-SNU2012	Dado	Tuerca	Moer
10	Insert G134 Gr22/4 sec.	Cache d'insertion	Mascherina	Chapa cuadro	Paneel
11	Coll hood G144 3sect	ANTI REFOULEUR	Disp. Controllo corrento	Seguro evacuación	Trekonderbreking
12	Clean-out cover G144 3sect	Couvercle	Coperchio nero	Tapa	Deksel
13	Gasket kit PK-W11 cartridge	MASTIC PK-W11 310 ML	Kit	Mastique	Kit
14	Flow bracket R 1" 357 long	EQUERRE CIRCUIT	Staffa	Angulo	Hoeksteun
15	Return bracket R 1" 92 long	EQUERRE CIRCUIT	Staffa	Angulo	Hoeksteun
16	Tee	RACC T COMPLET	Raccordo a T	Pieza en T	T-stuk
17	Gasket AFM34, white	Joint AFM34,blanc	Guarnizione	Junta	Afdichting
18	Gasket EPDM80IRHD, black	Joint EPDM80IRHD,noir	Guarnizione	Junta	Afdichting
19	Connection for Heating return	RACC CIRC	Raccordo di collegamento	Racor	Aansluitstuk
20	Gasket C4400 Klinger SIL,	JOINT 27X38X2	Guarnizione 27x38x2mm	Junta 27x38x2mm	Afdichting 27x38x2mm
21	Exhaust resignation fuse G144	Exhaust resignation fuse			
22	Partition G144	Paroi intermediaire	Parete intermedia	Pared intermedia	Tussenwand
23	Sensor well R3/4"x100mm	DOIGT DE GANT		Casquillo de la caldera	
24	Cross brace bw G144	Traverse	Traversa	Placa de unión	Vangschaal
26	Edge protection kit	PROTECT BORDS			
27	Installation material boiler block	VISSERIE G124			
28	installation mat draft inducer				
3	Element of construction	Groupe construction	Gruppo costruzione	Grupo construccion	Montagegroep
1	Cover G144	Couvercle avant	Coperchio anteriore	Pared delantero	Voorwand
2	Badge R=776 Logano G144	Badge	Badge	Badge	Badge
3	Side panel	HABIL LAT G124 X	Side panel	Side panel	Side panel
4	Cable clip	ATTACHE RAPIDE	Angolare	Cable clip	Houder
5	Hood fr G124X/G144	HABIL AVANT G124 X	Carpot	Capota	Deksel
6	Hood rr G124X	HABIL SUP AR G124	Carpot	Capota	Deksel
7	Angle with knurled bolts	EQUERRE 3X30/20X463	Staffa	Angulo	Hoeksteun
8	Rr panel G144	Dosseret	Schienale	Respaldo	Achterwand
9	Heat insu boiler bl sect	Isolation corps de chaud.	Heat insu boiler bl	Heat insu boiler bl	Heat insu boiler bl
10	Retaining spring 10Pc mverp	Ressorts de retenue	Molla	Clip de fijacion	Borgveer
12	Installation material	MATERIEL MONTAGE			Installation material
4	Element of construction	Groupe construction	Gruppo costruzione	Grupo construccion	Montagegroep
1	Gasket C4400 Klinger SIL,	JOINT 27X38X2	Guarnizione 27x38x2mm	Junta 27x38x2mm	Afdichting 27x38x2mm
2	Flow pipe KAS1 V2	Tube départ compl.KAS1	Tubo di mandata	Tubo de salida	Aanvoerleiding
3	Gasket C4400 Klinger SIL,	JOINT 27X38X2	Guarnizione 27x38x2mm	Junta 27x38x2mm	Afdichting 27x38x2mm
4	Return pipe G1 1/4KAS1 V2	Tube retour G 1 1/4 compl.	Tubo di ritorno	Tubo de retorno	Retourleiding
5	Tee	RACC T COMPLET	Raccordo a T	Pieza en T	T-stuk
6	Locking cap G1	BOUCHON KAS 2 G1	Sigillo	Locking cap	Beschermkap
7	Gasket EPDM80IRHD, black	Joint EPDM80IRHD,noir	Guarnizione	Junta	Afdichting
8	Gasket AFM34 10x everp	Joint	Guarnizione	Junta	Afdichting
5	Element of construction	Groupe construction	Gruppo costruzione	Grupo de construccion	Montagegroep
1	Gasket C4400 Klinger SIL,	JOINT 27X38X2	Guarnizione 27x38x2mm	Junta 27x38x2mm	Afdichting 27x38x2mm

Übersetzungsliste
List of translations

Liste des traductions
Traduzione delle descrizioni

Lista de traducciones
Vertalinglijst

Pos	Description	Denomination	Descrizione	Descripción	Benaming
2	Part insert for MFV	MANCHON MFV	Pezzo da inserire	Pieza de inserción	Inlegstuk
3	gasket kit O-seal V2	Jeu de joints	Set di guarnizioni	gasket kit O-seal V2	Set afdichting
4	Angle G1 1/4" for MFV	COUDE POUR MFV	Staffa	Angulo	Hoeksteun
5	Gasket Klinger SIL	JOINT 27X38X2	Guarnizione 27x38x2mm	Junta 27x38x2mm	Afdichting 27x38x2mm
6	Distributor MFV	EMBRANCHEMENT	Distributore	Boquilla de purga	Kortsluitleiding
8	Extension kit for KAS 2for boiler	RALLONGE RACCORD			
9	Flow pipe G1 1/4 for KAS2	TUBUL DEPART KAS2	Tubo di mandata	Tubo de salida	Aanvoerleiding
10	Return pipe G1 1/4 for KAS2	Tube retour compl.pour KAS2	Tubo di ritorno	Tubo de retorno	Retourleiding
11	Tee	RACC T COMPLET	Raccordo a T	Pieza en T	T-stuk
12	Locking cap G1	BOUCHON KAS 2 G1	Sigillo	Locking cap	Beschermkap
13	Gasket EPDM80IRHD, black	Joint EPDM80IRHD,noir	Guarnizione	Junta	Afdichting
14	Gasket AFM34 10x everp	Joint	Guarnizione	Junta	Afdichting
	Thermal insulation for MFV deep	ISOL KAS2 G115			
6	Element of construction	Groupe construction	Gruppo costruzione	Grupo construccion	Montagegroep
1	Gasket AFM34 10x everp	Joint	Guarnizione	Junta	Afdichting
2	Connecting pipe for boiler	TUBUL RACC	Tubo di raccordo	Connecting pipe for boiler	Aansluitpijp
3	Distributor KSS V3	Collecteur KSS V3	Distributore	Boquilla de purga	Kortsluitleiding
4	Locking cap G1	BOUCHON KAS 2 G1	Sigillo	Locking cap	Beschermkap
5	Gasket EPDM80IRHD, black	Joint EPDM80IRHD,noir	Guarnizione	Junta	Afdichting
6	Membrane safety valve MS for clos	SOUPAPE DE SECURITE	Valvola sicurezza	Válvula de sobrepresión	Veiligheidsklep
7	Pressure gauge for closed conn.,	Manomètre pour install.	Manometro	Manómetro	Manometer
8	Air vent shut-off valve	PURGEUR AUTOM			
9	Thermal insulation safety kit	Isolation			
10	gasket kit O-seal V2	Jeu de joints	Set di guarnizioni		Set afdichting
11	Double nipple G1xG1 89 long	RALLONGE LG 89 MM	Nipples doppio	Manguito roscado doble	Nippel
12	Fill and Drain valve G1XG3/4	ROBIN REPLIS	Valve	Valvola	Kraan
13	Gasket kit Flat gasket 1	JOINTS PLAT G 115	Gasket kit Flat gasket 1		Gasket kit Flat gasket 1
14	Metal hose DN20 1000mm long	TUBUL FLEX DN 20	Tubo flessibile	Tubo flexible	Slang
15	Cap valve G3/4xG3/4	Raccord d'arrêt	Valvola	Válvula de globo	Ventiel
16	O-ring 22x2,5 70EPDM/281	Joint torique	Anello tenuta	Anillo tórico	O-ring
17	Reducing piece	Réduction			
7	Element of construction	Groupe construction	Gruppo costruzione	Grupo construccion	Montagegroep
1	flow pipe HS/V G144V	Tube départ	Tubo di mandata	Tubo de salida	Aanvoerleiding
2	Gasket D24x30.5x2mm AFM34 10	Joint	Guarnizione	Junta	Afdichting
3	return pipe HS/V G144V	Tube retour	Tubo di ritorno	Tubo de retorno	Retourleiding
4	Ball valve VK CGM sets HS/V	Robinet à boule	Valvola a sfera	Válvula de bola	Kogelkraan
5	Ball valve RK CGM sets HS/V	Robinet à boule	Valvola a sfera	Válvula de bola	Kogelkraan
6	relief valve CGM sets HS/V	By-pass	Valvola di troppo pieno	Vavula de descarga	By-pass
7	Handle Ball valve G1 red	Poignée robinet G1 rouge	Manopola	Mando del grifo	Knop
8	Handle Ball valve G1 blue	Poignée robinet G1 bleu	Manopola	Mando del grifo	Knop
9	Thermometer	Thermomètre	Termometro	Termómetro	Thermometer
10	Sealing AFM34	Sealing			
8	Element of construction	Groupe construction	Gruppo costruzione	Grupo construccion	Montagegroep
1	Gasket AFM 34, white	JOINT	Guarnizione	Junta	Afdichting
2	flow R1 G144V	flow R1 G144V	flow R1 G144V	flow R1 G144V	flow R1 G144V
3	Air vent with shut-off valve	PURGEUR AUTOM			
4	Membrane safety valve MS 1/2	SOUPAPE DE SECURITE	Valvola sicurezza	Válvula de sobrepresión	Veiligheidsklep
5	Pressure gauge axial 0 -4 bar	Manomètre axialem. 0-4bar	Manometro	Manómetro	Manometer
6	distributor G3/4 breather		Distributore	Boquilla de purga	Kortsluitleiding
7	Return connection Tee	TUBUL BRANCHEMENT			
8	Gasket C4400 Klinger SIL,	JOINT D32X44X2	Guarnizione	Junta	Afdichting
9	Return connection R1"compl	Return connection compl			
10	Pump RS25/4-3 180mm	POMPE RS 25/4	Pompa	Bomba	Pomp
11	Pump UPS25-40 180mm	POMPE UPS 25-40	Pompa	Bomba	Pomp
12	return flow departure R1 G144V	return flow departure R1			
13	Fill and Drain valve	VANNE REPLISSAGE	Fill and Drain valve	Fill and Drain valve	Fill and Drain valve
14	Cap valve G3/4-G3/4	Vanne d'isolement	Valvola	Válvula de globo	Ventiel

Bosch Thermotechnik GmbH
Sophienstraße 30-32
D-35576 Wetzlar
www.buderus.de

Buderus